



FRIENDS OF HUE SMART SWITCH

GETTING SETUP



Set the mood, dim the lights and take full control of your Philips Hue lighting with Retrotouch smart switches. Simply replace your existing light switches for an always-on Hue experience or stick to any wall for a wireless battery free operation.

OPTION 1

Stick anywhere

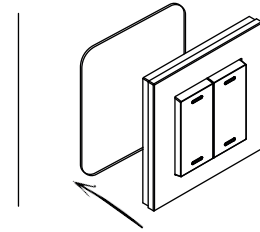

Clean & dry the surface you wish to stick the switch too. Use the 3M sticky pads and locate on the back of the switch. Peel and Stick. Apply pressure for 10 seconds to get a firm fix.

OPTION 2 - Recommended for an always-on Hue experience

Replace your existing light switch

IMPORTANT: Before commencing any electrical work ensure the supply is switched **OFF** at the mains. Either by switching off the consumer unit or by removing the appropriate fuse.

a. Remove the existing switch from its location and disconnect the wiring.

b. Connect wires using the supplied terminal block to create an always on circuit.

c. Scan the QR code below or visit: www.retrotouch.co.uk/setup-friends-of-hue-switch for more details on wiring.

d. Ensure terminals are properly tightened and ensure no bare wires are visible.

When pushing back into the backbox ensure no wires are trapped.

If in any doubt, Please contact a qualified electrician.

1 Fix to the backbox

Use a flat head screwdriver and insert in the slot at the base of the switch, Hold the glass with one hand and twist the screwdriver slowly and the glass panel will pop off.

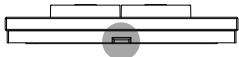

Use the screws provided to secure the Smart switch to the backbox so there is no movement. Do not over tighten.

2 Attach the Glass

Align the top edge of the glass to the top edge of the back plate, you will see up arrows at the top. Then push down firmly until you hear a click and the glass panel is locked in place.

3 Ready to setup

To setup the switch in the Philips Hue App you will need to leave the 2 buttons in place. Note the Philips Hue lights must be on for setup.

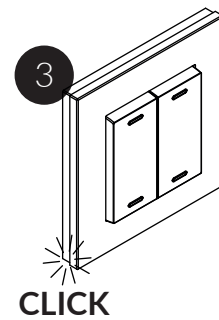
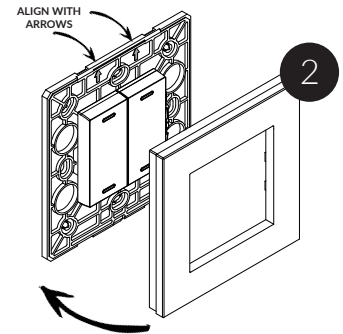
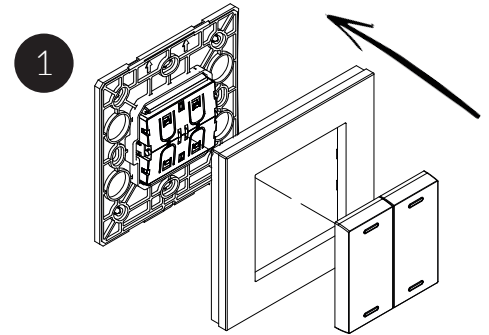

For install videos & guides visit our website

What you need

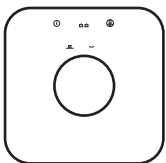

Requires a Philips Hue Bridge (v2) and Philips Hue app for Android or iOS for initial setup.



Learn more on meethue.com

Configure Switches

Use the Philips Hue App on your phone or tablet to set up your switch.

1. Open the Philips Hue App
2. Click on 'Settings'
3. Select 'Add Accessory'
4. Select 'Friends of Hue Switch'
5. Pick Retrotouch Friends of Hue Switch
6. Your switch will now be connected.

The app will guide you through configuring your new smart switch.

Need Help?

Open your phone's camera and scan this QR code...



Visit our website for videos and how to guides or contact our support team at support@retrotouch.co.uk

For matching sockets visit: www.retrotouch.co.uk

Whats in the box

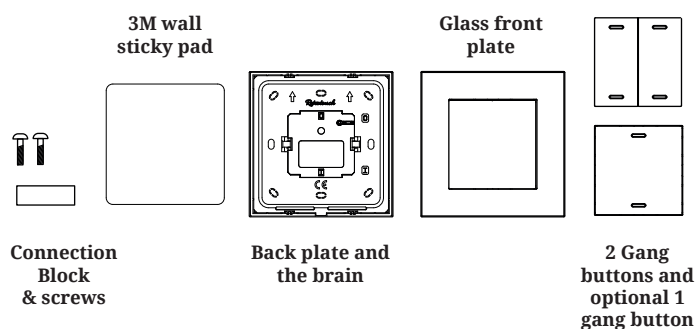

NOTE: Please keep all buttons in a safe place in case you make changes to your system.

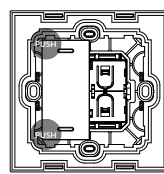

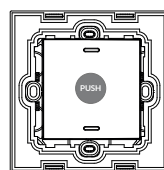

To remove buttons



Back plate and the brain

(Optional) 1 Gang Button

Once configured you can then swap to 2 gang buttons for a 1 gang button.

To remove the 2 gang buttons, press and hold the corners and the buttons and they will pop off. Then align the 1 gang button with the  at the top and the  at the bottom and push in the centre to lock in place. You will feel it click in place.

Note: In the Philips Hue App, you will still see the 2 button setup as before but only the left side of the switch will now trigger actions like On/Off or Dimming.

FOR RESIDENTIAL USE

Please ensure Hue lamp is plugged in and always switched ON. The Hue lamp can only be controlled by the Hue system when the light is powered on.

SAFETY INFORMATION

Before use please read carefully and use in accordance with these safety instructions.

Before commencing any electrical work ensure the supply is switched OFF at the mains. Either by switching off the consumer unit or by removing the appropriate fuse.

This product should be installed in accordance with the relevant sections of the building regulations code and in accordance with the latest edition of IEE regulations (BS 7671).

If the unit is to be used as a replacement for an existing light switch, remove the existing unit from its location and disconnect the wiring. Use the connection block to create a always on circuit.

Ensure terminals are properly tightened and ensure no bare wires are visible. When pushing back into the backbox ensure no wires are trapped.

Read the instructions carefully before starting the installation process and keep them safe for future reference.

IF IN ANY DOUBT, PLEASE CONTACT A QUALIFIED ELECTRICIAN.

PRIVACY POLICY

Full privacy policy and terms and conditions can be found at www.retrotouch.com/privacy. Please be informed that Signify will have access to your personal and usage data via the Hue bridge. In order to understand how Signify processes your personal data and usage data please read respectively Signify's privacy notice and terms of use which can be found on www.meethue.com.

REGULATORY INFO

All regions

Modifications made to the product, unless expressly approved by Retrotouch (UK) Limited, could void the user's authority to operate the equipment.

Europe – EU Declarations of Conformity

Retrotouch (UK) Limited declare under our sole responsibility that the product(s) Friends of Hue Smart Switch, Model Number(s) RT-FOH-SS is/are in conformance with the following standards:

- EN301489-17:V3.2.0
- EN61000-6-2:2005
- EN61000-6-4:2007+A1:2011
- EN300328:V2.1.1
- EN60950-1:2006+A11:2009+A1:2010+A12:2011+A2:2013
- EN60669-1:2018
- EN62479:2010

Following the provisions of the Directive 2014/53/EU.

A copy of the EU declaration of conformity is available online at www.retrotouch.co.uk/compliance.

North America – FCC & IC Compliance

Contains FCC ID: SZV-PTM215Z
Contains IC: 5713A-PTM215Z

Canada (IC) requirements

Complies with Canadian ICES-003 and also with part 15 of the FCC rules. Operation is subject to the following conditions: (1) this device may not cause harmful interference, and (2) this device must accept any interference received including interference that may cause undesired operation.

Cet appareil numérique de la classe B est conforme à la norme NMB-003 du Canada ainsi qu'aux CNR d'Industrie Canada applicables aux appareils radio exempts de licence. L'exploitation est autorisée aux deux conditions suivantes: (1) l'appareil ne doit pas produire de brouillage, et (2) l'utilisateur de l'appareil doit accepter tout brouillage radioélectrique subi, même si le brouillage est susceptible d'en compromettre le fonctionnement.

The term "IC:" before the radio certification number only signifies that Industry Canada technical specifications were met.

Modifications made to the product, unless expressly approved by Retrotouch (UK) limited, could void the user's authority to operate the equipment.

US (FCC) requirements
See FCC & IC Compliance.

NOTE: This equipment has been tested and found to comply with the limits for a Class B digital device, pursuant to Part 15 of the FCC Rules. These limits are designed to provide reasonable protection against harmful interference in a residential installation. This equipment generates, uses, and can radiate radio frequency energy and, if not installed and used in accordance with the instructions, may cause harmful interference to radio communications. However, there is no guarantee that interference will not occur in a particular installation. If this equipment does cause harmful interference to radio or television reception, which can be determined by turning the equipment off and on, the user is encouraged to try and correct the interference by one or more of the following measures:

- Reorient or locate the receiving antenna
- Increase the separation between the equipment and receiver
- Connect the equipment into an outlet on a circuit different from that to which the receiver is connected
- Consult the dealer or an experienced radio/TV technician for help

Guarantee

This Smart switch is of excellent quality and construction. However, if any defects in materials or workmanship do appear during the guarantee period, we will, at our discretion, either repair or replace the defective parts, free of charge, subject to the terms and conditions of our Guarantee shown below.

This Guarantee covers both parts and labour. Carriage is not included. This Guarantee provides benefits which are additional to, and do not affect, your statutory rights. This Guarantee does not cover the cost of returning the product to the dealer from whom it was purchased or to ourselves. This Guarantee applies only to products sold and located in mainland Great Britain. It does not cover liability in respect of or replacement of plugs, cables or fuses and also does not cover defects due to:

- Failure to use or maintain product in accordance with Retrotouch instructions.
- Accidental damage to or abuse or misuse of the product.
- Product modification, except by Retrotouch or approved agent.
- Dismantling of or interference with the product.

Before returning any product under this Guarantee, please check that:

- You have followed the product instructions correctly.

If you wish to claim under this guarantee you should:

- Send the product, postage or carriage paid, to the dealer from whom it was purchased or to Retrotouch direct.
- Ensure that the product is clean and packed carefully (preferably in its original carton).

- Enclose details of your name, address and telephone number and when and where the product was purchased, together with proof of purchase (e.g. a invoice or till receipt).
- Give exact details of the nature of the defect.

This Guarantee does not cover any other claims whatsoever, including, without limitation, any liability for incidental, indirect or consequential damage, nor does it cover any claims for conversion or modification or for the costs of repair carried out by any third party without the prior consent of Retrotouch. If replacement parts are fitted to the product this will not extend

Apple and the Apple logo are trademarks of Apple Inc., registered in the U.S. and other countries. App Store is a service mark of Apple Inc.

Google Play is a trademark of Google Inc.

Hue, Friends of Hue, and all related logos are trademarks of Signify Holding. Philips is a trademark of Koninklijke Philips N.V.